

80% of Actual Size
Sublimation

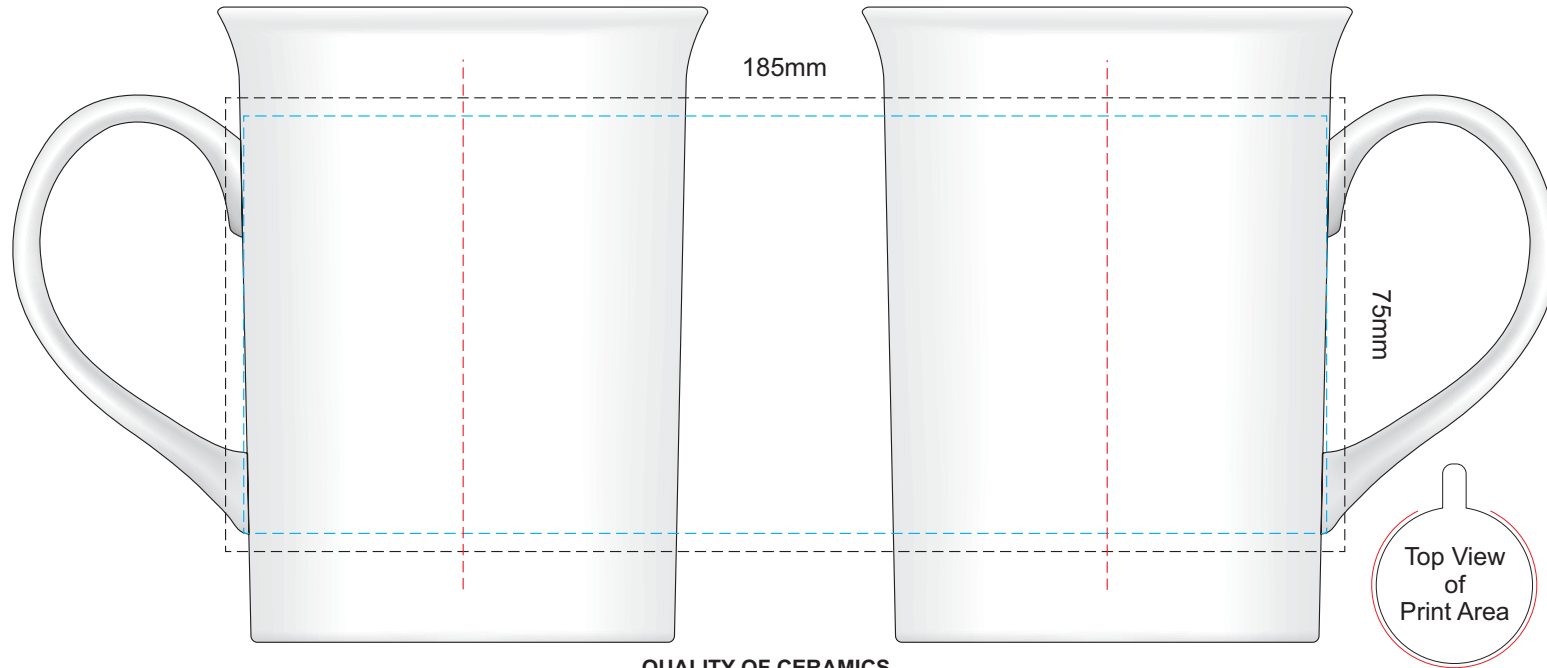

QUALITY OF CERAMICS

Due to the inherent properties of ceramic ware produced by foreign manufacturers, there may be small imperfections or irregularities which should not be perceived as defective. Variations in materials, firing temperatures and colour pigments may result in variations in glaze and imprint colours. These variations must be considered acceptable.

Blue Line = The SIGNIFICANT PRINT AREA

(Keep all critical images & text within this box)

Black Line = Maximum print area

Red Line = Exact opposites of the product

(centre artwork to the red line)

100% of Actual Size
Digital Print

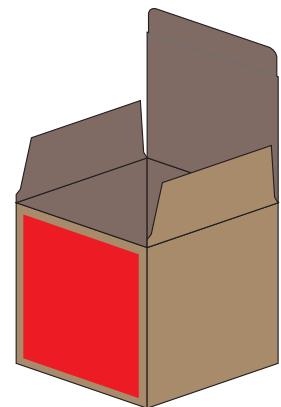
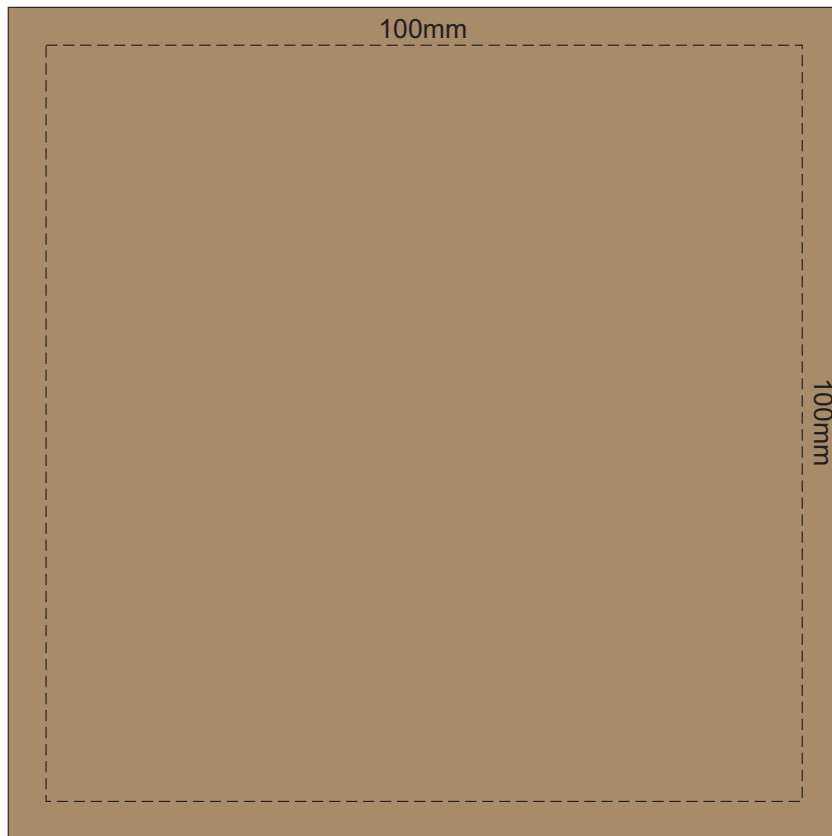

GIFT BOX
FRONT

Artwork will be printed directly onto the product via CMYK printing (no white), colours will not be vibrant due to white ink not being available for this process.

GIFT BOX SLEEVE

60% of Actual Size
Digital Label
423mm

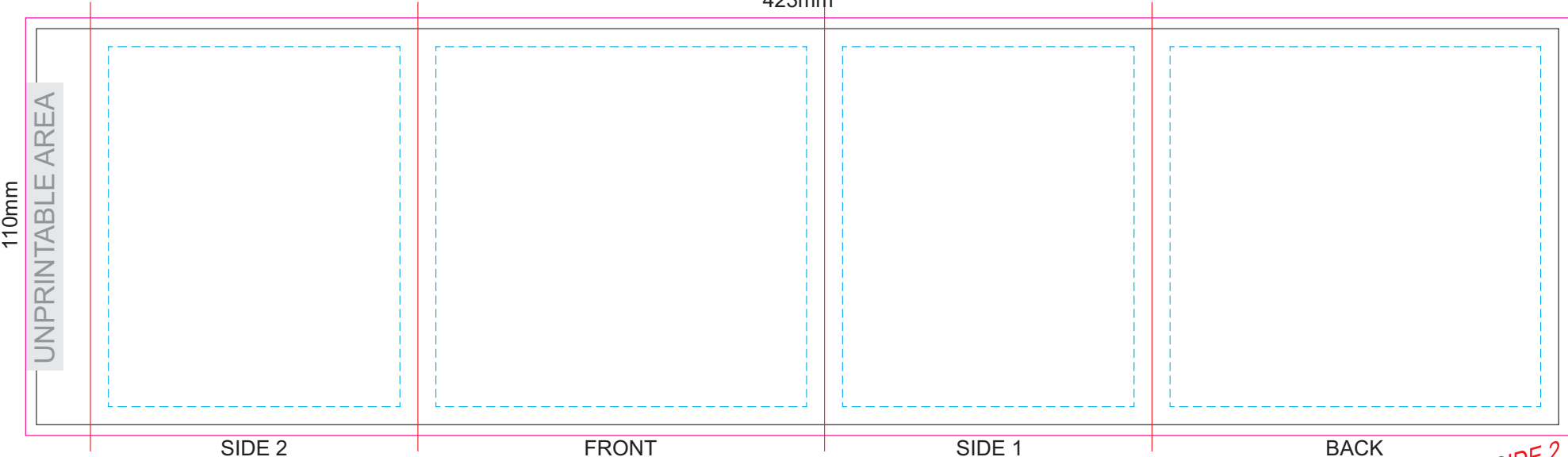

Blue Line = The SIGNIFICANT PRINT AREA
(Keep all critical images & text within this box)
Black Line = Maximum print area
Pink Line = Bleed off to here
Red Line = Fold Line

